



HISTORY

Designed by Hans J. Wegner in 1962.

DESCRIPTION

Hans J. Wegner wanted to design a dining table well suited for the CH24 dining chair. He designed this beautiful solid wood table, CH327 and even though it is intended for dining it also makes a handsome and functional desk or meeting table.

The table achieves an elegant lightness due to the tapered edges of the table top, which nearly floats above the frame.

The rounded legs finish the overall impression of effortless agility, as they taper elegantly from the frame to the floor.

The table top is made from uninterrupted sections of solid wood running the entire length of the table. This solution compared to full-width table tops, results in a more harmonious surface, and is considerably more difficult to produce.

The table is often purchased together with CH24, "The Wishbone Chair", but it also works beautifully with CH36/CH37 and CH46/47.

The table accommodates up to two extension leaves.

The extension leaves can be ordered separately. It is advisable to order the leaves together with the table to avoid variation in colour.

Made from solid hardwood.

[Download assembly instructions](#)

ENVIRONMENTAL INFORMATION

Carl Hansen & Søn and sustainability

People's fascination of the combination of good design and wood, as well as other natural materials, is something that transcends time and fashion. At Carl Hansen & Søn, we believe that this fascination helps to explain the great interest in our furniture, and we take very seriously concerns about the sustainability of the natural resources upon which we depend for our products. That is why we strive every day to improve our production methods, logistics and sales efforts in respect of scarce natural resources.

We buy wood only from sustainably managed forests. All sourced wood meets EUTR 2013 regulations, Danish Forest Legislation and current international certifications. Oak, beech and ash come primarily from Danish forests which are managed according to the principles described in Denmark's National Forest Programme; some of these wood types are also sourced from other similarly managed European forests, or, in the case of walnut and cherry, North American forests.

We use every possible bit of these fine hardwoods in our furniture production. Inevitably, however, there are some scraps, which are then used to produce

Japan

+81 3 5413 5421

Carl Hansen & Søn HK Limited

16th Floor, 202 Centre
202-204 Des Vieux Road West
Hong Kong

+852 5631 0267

ml@carlhansen.com

AMERICA

Carl Hansen & Søn Corp

304 Hudson Street
3rd Floor
New York, NY 10013
USA

Tel: +1 212 242 6736

northamerica@carlhansen.com

Carl Hansen & Søn Showroom Los Angeles

8745 Washington Boulevard
Studio B
Culver City, CA 90232
Tel.: + 1 (310) 842-8656

THE DESIGNER

Hans J. Wegner was born in 1914 in Tønder, the son of a shoemaker. At the age of 17 he was apprenticed to a carpenter (H. F. Stahlberg) and it was at this time that he developed his first design. At the age of 20 he moved to Copenhagen to study at the institution now known as The Royal Danish Academy of Fine Arts, School of Design but which back then went under the more modest title of "The Artisan College."

He studied there from 1936-1938, before taking further studies as an architect. In 1940 Wegner initiated a joint project with Arne Jacobsen and Erik Møller in Aarhus, which involved fitting out Aarhus' town hall. It was also in 1940 that Wegner began to work with Master Carpenter Johannes Hansen, a man who played a significant role in bringing modern design to the Danish public. The then Copenhagen Industrial Art Museum (now Design Museum Denmark) purchased their first Wegner chair in 1942. **Hans J. Wegner** opened his own design studio in 1943, and in 1944 he designed his first "China Chair" in a series inspired by the Chinese Emperor's thrones.

One of the chairs in this series is what is probably Wegner's most famous work **The Wishbone Chair** which he designed in 1949, and which Carl Hansen & Søn have manufactured since 1950. **Hans J. Wegner** is regarded

other products or recycled in district heating plants.

CONTACT INFORMATION

EUROPE

Carl Hansen & Søn A/S

Hylkedamvej 77-79
Bygning 2
DK 5591 Gelsted
Denmark

Tel: +45 66 12 14 04
Fax: +45 65 91 60 04
info@carlhansen.com

Carl Hansen & Søn Flagship Store

Bredgade 21
1260 Copenhagen K
Denmark

Phone: +45 64 47 23 60
retail@carlhansen.dk

Carl Hansen & Søn Showroom Oslo

Drammensveien 130 B9
0277 Oslo
Norway

Contract
+47 926 83 994
mh@carlhansen.dk

Retail
+47 900 77 087
hrs@carlhansen.dk

Carl Hansen & Søn Showroom London

16 Bowling Green Lane
London
EC1R 0BD
United Kingdom

Tel: +44 (0) 20 7632 7587
Mail: ukinfo@carlhansen.com

Carl Hansen & Søn Showroom Milan

Piazza Paolo VI
Via Delio Tessa
20121 Milan
Italy

+39 340 4266636
oc@carlhansen.dk

ASIA/PACIFIC

Carl Hansen & Søn Japan K.K.

2F Hills Aoyama, 3-39-9 Jingumae
Shibuya-ku 150-0001
Tokyo, Japan

Tel: +81 3 5413 6771
Fax: +81 3 5413 6772
info@carlhansen.jp

Carl Hansen & Søn Flagship Store Japan

Aoyama Artworks 1/2F
2-5-10 Jingumae
Shibuya-ku, Tokyo, 150-0001

as one of the world's outstanding furniture designers. He was one of the motive forces behind the Danish Modern movement which did much to change people's view of furniture in the 1950s and 60s. His design retain relevance for us today and his sense for details is a source of constant wonder.

Wegner has received a number of prizes and recognitions. Amongst other things, he is an honorary member of The Royal Danish Academy of Fine Arts and has received an honorary doctorate from the Royal College of Art in London. He was also the first ever recipient of the Lunning Prize and received the 8th International Design Award in Osaka, Japan. His works are exhibited at major international museums including The Museum of Modern Art (MoMA) in New York and Die Neue Sammlung in Munich.

Hans J. Wegner died in Denmark in January 2007.

Hans J. Wegner's contributions to Danish design:

- A master carpenter first and a designer second: Perfectly finished joints and exquisite forms.
- A deep respect for the wood and its character and an everlasting curiosity about good materials.
- He gave minimalism an organic and natural softness.
- He is considered as "the master chair-maker" and designed more than 500 chairs during the course of his life.

Experience Wegner's iconic Wishbone Chair

Watch the making of the Wishbone Chair

VARIANTS CHOICES AND DIMENSIONS

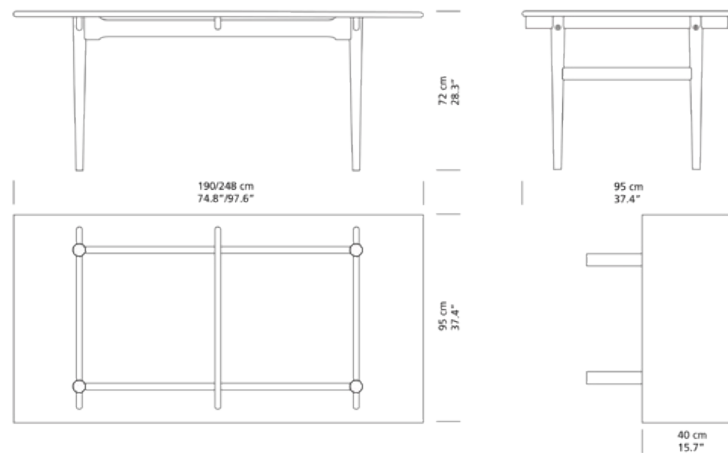

MATERIAL MATRIX

	Soap	Lacquer/Oil	White oil
Ash	●	●	●
Beech	●	●	
Oak	●	●	●
Walnut		●	

Oak and ash have a clearly visible wood structure when painted. Beech has minimal structure when painted. Oak is available only in black (NCS S9000-N).

TESTS AND CERTIFICATIONS

All tests and certificates are available on request.